

# SERVICE MANUAL

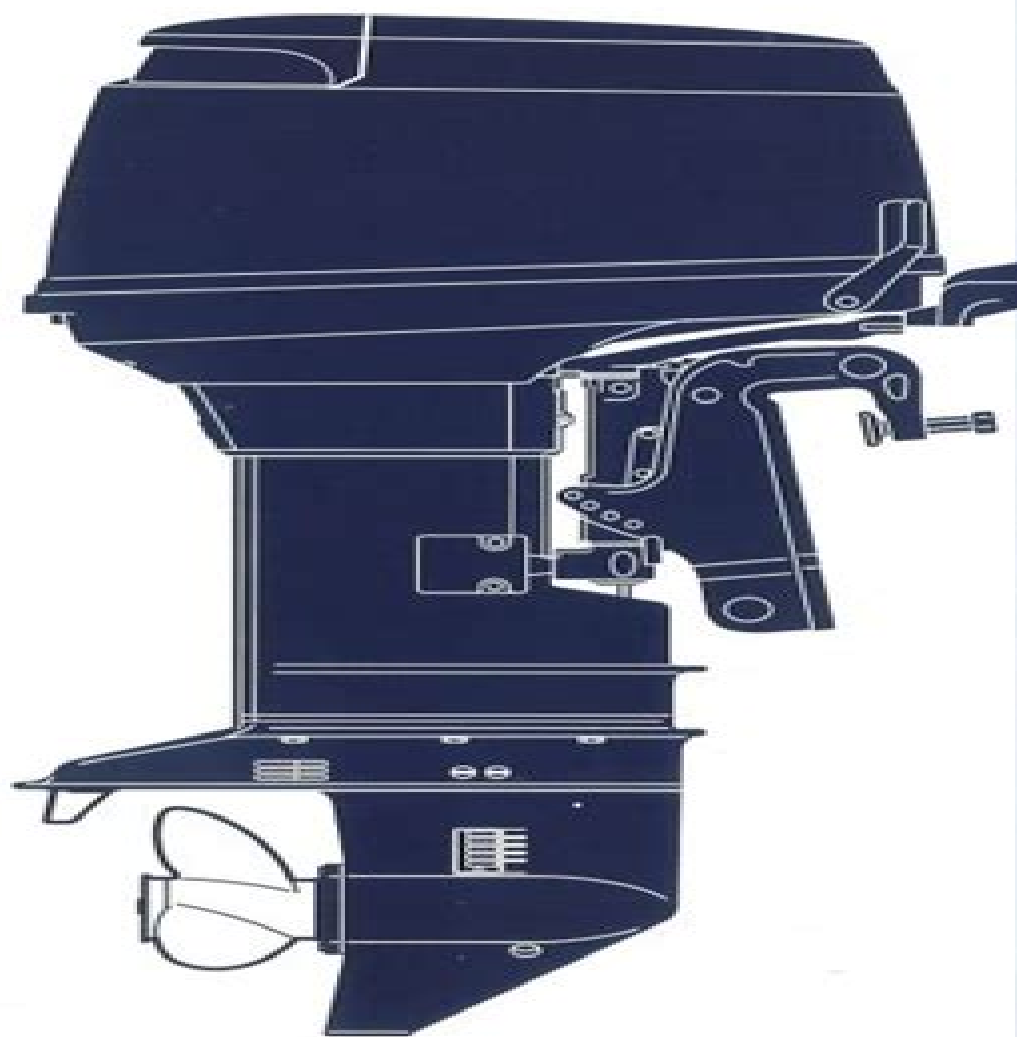

 **TOHATSU**  
Outboards

*TFDI*  
**MD 30B2  
40/50B2  
Models**

OB No.003-21050-3  
13-10 NB

# Tohatsu Md 50 Service Manual

**D Keegan**



## **Tohatsu Md 50 Service Manual:**

Embark on a transformative journey with is captivating work, Grab Your Copy of **Tohatsu Md 50 Service Manual** . This enlightening ebook, available for download in a convenient PDF format PDF Size: , invites you to explore a world of boundless knowledge. Unleash your intellectual curiosity and discover the power of words as you dive into this riveting creation. Download now and elevate your reading experience to new heights .

<https://hersolutiongelbuy.com/About/detail/fetch.php/Seacuterie%20Noire%20Agrave%20Lescalegraves.pdf>

## **Table of Contents Tohatsu Md 50 Service Manual**

1. Understanding the eBook Tohatsu Md 50 Service Manual
  - The Rise of Digital Reading Tohatsu Md 50 Service Manual
  - Advantages of eBooks Over Traditional Books
2. Identifying Tohatsu Md 50 Service Manual
  - Exploring Different Genres
  - Considering Fiction vs. Non-Fiction
  - Determining Your Reading Goals
3. Choosing the Right eBook Platform
  - Popular eBook Platforms
  - Features to Look for in an Tohatsu Md 50 Service Manual
  - User-Friendly Interface
4. Exploring eBook Recommendations from Tohatsu Md 50 Service Manual
  - Personalized Recommendations
  - Tohatsu Md 50 Service Manual User Reviews and Ratings
  - Tohatsu Md 50 Service Manual and Bestseller Lists
5. Accessing Tohatsu Md 50 Service Manual Free and Paid eBooks
  - Tohatsu Md 50 Service Manual Public Domain eBooks
  - Tohatsu Md 50 Service Manual eBook Subscription Services
  - Tohatsu Md 50 Service Manual Budget-Friendly Options

6. Navigating Tohatsu Md 50 Service Manual eBook Formats
  - ePub, PDF, MOBI, and More
  - Tohatsu Md 50 Service Manual Compatibility with Devices
  - Tohatsu Md 50 Service Manual Enhanced eBook Features
7. Enhancing Your Reading Experience
  - Adjustable Fonts and Text Sizes of Tohatsu Md 50 Service Manual
  - Highlighting and Note-Taking Tohatsu Md 50 Service Manual
  - Interactive Elements Tohatsu Md 50 Service Manual
8. Staying Engaged with Tohatsu Md 50 Service Manual
  - Joining Online Reading Communities
  - Participating in Virtual Book Clubs
  - Following Authors and Publishers Tohatsu Md 50 Service Manual
9. Balancing eBooks and Physical Books Tohatsu Md 50 Service Manual
  - Benefits of a Digital Library
  - Creating a Diverse Reading Collection Tohatsu Md 50 Service Manual
10. Overcoming Reading Challenges
  - Dealing with Digital Eye Strain
  - Minimizing Distractions
  - Managing Screen Time
11. Cultivating a Reading Routine Tohatsu Md 50 Service Manual
  - Setting Reading Goals Tohatsu Md 50 Service Manual
  - Carving Out Dedicated Reading Time
12. Sourcing Reliable Information of Tohatsu Md 50 Service Manual
  - Fact-Checking eBook Content of Tohatsu Md 50 Service Manual
  - Distinguishing Credible Sources
13. Promoting Lifelong Learning
  - Utilizing eBooks for Skill Development
  - Exploring Educational eBooks
14. Embracing eBook Trends
  - Integration of Multimedia Elements

- Interactive and Gamified eBooks

### **Tohatsu Md 50 Service Manual Introduction**

In today's digital age, the availability of Tohatsu Md 50 Service Manual books and manuals for download has revolutionized the way we access information. Gone are the days of physically flipping through pages and carrying heavy textbooks or manuals. With just a few clicks, we can now access a wealth of knowledge from the comfort of our own homes or on the go. This article will explore the advantages of Tohatsu Md 50 Service Manual books and manuals for download, along with some popular platforms that offer these resources. One of the significant advantages of Tohatsu Md 50 Service Manual books and manuals for download is the cost-saving aspect. Traditional books and manuals can be costly, especially if you need to purchase several of them for educational or professional purposes. By accessing Tohatsu Md 50 Service Manual versions, you eliminate the need to spend money on physical copies. This not only saves you money but also reduces the environmental impact associated with book production and transportation. Furthermore, Tohatsu Md 50 Service Manual books and manuals for download are incredibly convenient. With just a computer or smartphone and an internet connection, you can access a vast library of resources on any subject imaginable. Whether you're a student looking for textbooks, a professional seeking industry-specific manuals, or someone interested in self-improvement, these digital resources provide an efficient and accessible means of acquiring knowledge. Moreover, PDF books and manuals offer a range of benefits compared to other digital formats. PDF files are designed to retain their formatting regardless of the device used to open them. This ensures that the content appears exactly as intended by the author, with no loss of formatting or missing graphics. Additionally, PDF files can be easily annotated, bookmarked, and searched for specific terms, making them highly practical for studying or referencing. When it comes to accessing Tohatsu Md 50 Service Manual books and manuals, several platforms offer an extensive collection of resources. One such platform is Project Gutenberg, a nonprofit organization that provides over 60,000 free eBooks. These books are primarily in the public domain, meaning they can be freely distributed and downloaded. Project Gutenberg offers a wide range of classic literature, making it an excellent resource for literature enthusiasts. Another popular platform for Tohatsu Md 50 Service Manual books and manuals is Open Library. Open Library is an initiative of the Internet Archive, a non-profit organization dedicated to digitizing cultural artifacts and making them accessible to the public. Open Library hosts millions of books, including both public domain works and contemporary titles. It also allows users to borrow digital copies of certain books for a limited period, similar to a library lending system. Additionally, many universities and educational institutions have their own digital libraries that provide free access to PDF books and manuals. These libraries often offer academic texts, research papers, and technical manuals, making them invaluable resources for students and researchers. Some notable examples include MIT OpenCourseWare, which offers free access to course materials from

the Massachusetts Institute of Technology, and the Digital Public Library of America, which provides a vast collection of digitized books and historical documents. In conclusion, Tohatsu Md 50 Service Manual books and manuals for download have transformed the way we access information. They provide a cost-effective and convenient means of acquiring knowledge, offering the ability to access a vast library of resources at our fingertips. With platforms like Project Gutenberg, Open Library, and various digital libraries offered by educational institutions, we have access to an ever-expanding collection of books and manuals. Whether for educational, professional, or personal purposes, these digital resources serve as valuable tools for continuous learning and self-improvement. So why not take advantage of the vast world of Tohatsu Md 50 Service Manual books and manuals for download and embark on your journey of knowledge?

### **FAQs About Tohatsu Md 50 Service Manual Books**

1. Where can I buy Tohatsu Md 50 Service Manual books? Bookstores: Physical bookstores like Barnes & Noble, Waterstones, and independent local stores. Online Retailers: Amazon, Book Depository, and various online bookstores offer a wide range of books in physical and digital formats.
2. What are the different book formats available? Hardcover: Sturdy and durable, usually more expensive. Paperback: Cheaper, lighter, and more portable than hardcovers. E-books: Digital books available for e-readers like Kindle or software like Apple Books, Kindle, and Google Play Books.
3. How do I choose a Tohatsu Md 50 Service Manual book to read? Genres: Consider the genre you enjoy (fiction, non-fiction, mystery, sci-fi, etc.). Recommendations: Ask friends, join book clubs, or explore online reviews and recommendations. Author: If you like a particular author, you might enjoy more of their work.
4. How do I take care of Tohatsu Md 50 Service Manual books? Storage: Keep them away from direct sunlight and in a dry environment. Handling: Avoid folding pages, use bookmarks, and handle them with clean hands. Cleaning: Gently dust the covers and pages occasionally.
5. Can I borrow books without buying them? Public Libraries: Local libraries offer a wide range of books for borrowing. Book Swaps: Community book exchanges or online platforms where people exchange books.
6. How can I track my reading progress or manage my book collection? Book Tracking Apps: Goodreads, LibraryThing, and Book Catalogue are popular apps for tracking your reading progress and managing book collections. Spreadsheets: You can create your own spreadsheet to track books read, ratings, and other details.
7. What are Tohatsu Md 50 Service Manual audiobooks, and where can I find them? Audiobooks: Audio recordings of

- books, perfect for listening while commuting or multitasking. Platforms: Audible, LibriVox, and Google Play Books offer a wide selection of audiobooks.
8. How do I support authors or the book industry? Buy Books: Purchase books from authors or independent bookstores. Reviews: Leave reviews on platforms like Goodreads or Amazon. Promotion: Share your favorite books on social media or recommend them to friends.
  9. Are there book clubs or reading communities I can join? Local Clubs: Check for local book clubs in libraries or community centers. Online Communities: Platforms like Goodreads have virtual book clubs and discussion groups.
  10. Can I read Tohatsu Md 50 Service Manual books for free? Public Domain Books: Many classic books are available for free as they're in the public domain. Free E-books: Some websites offer free e-books legally, like Project Gutenberg or Open Library.

**Find Tohatsu Md 50 Service Manual :**

[seacuterie noire agrave lescalegraves](#)

**seagate medalist 3240 3227mb storage owners manual**

~~sears brad nailer manual~~

**sears he4t manual**

~~searchable 2005 factory sea doo seadoo repair manual~~

[seabiscuit movie study guide](#)

*seagate momentus 5400 6 500gb storage owners manual*

**seadoo owners manual 2015**

[seam 2 x web development salter david](#)

[searchable factory yamaha vxr vxr pro repair manual](#)

~~seadoo xp owners manual~~

[screaming in the silence english edition](#)

**sea doo rxt owners manual**

[seacutevices compris presbyte](#)

**sears appliance repair ripoff**



**Tohatsu Md 50 Service Manual :**

*the maverick men of the saddle 3 amazon singapore* - Apr 17 2023

web the maverick men of the saddle book 3 ebook copeland lori amazon com au kindle store

the maverick men of the saddle 3 lori copeland - Jan 02 2022

**the plainsman men of the saddle series by copeland lori** - Feb 03 2022

web jan 1 2005 the maverick men of the saddle 3 lori copeland on amazon com free shipping on qualifying offers the maverick men of the saddle 3

the maverick men of the saddle 3 hardcover jan 1 2005 - Apr 05 2022

web amazon com the maverick men of the saddle 3 audible audio edition lori copeland cecilia ridett recorded books audible books originals

*the maverick men of the saddle the men of the saddle series* - Feb 15 2023

web created with sketch sample add to wishlist the maverick men of the saddle by lori copeland narrated by cecilia ridett unabridged 8 hours 57 minutes lori copeland

**the maverick book by lori copeland thriftbooks** - Aug 09 2022

web book three in the popular men of the saddle series by beloved author lori copeland six years ago susanne mccord tricked cass claxton into marrying her in a shotgun

the maverick men of the saddle 3 softcover abebooks - Nov 12 2022

web sorry there was a problem saving your cookie preferences try again

**men of the saddle series books goodreads** - Sep 10 2022

web the maverick is an excellent addition to the men of the saddle series cass claxton the bad boy of the claxton brothers has met his match he s on his way home from visiting

**the maverick men of the saddle book 3 kindle edition** - Oct 11 2022

web books shelved as men of the saddle series the maverick by lori copeland the drifter by lori copeland the plainsman by lori copeland and the peacemaker

**amazon com the maverick men of the saddle the men of the** - May 18 2023

web hello sign in account lists returns orders cart

*amazon com the maverick men of the saddle 3 audible* - Mar 04 2022

web dec 26 2005 the plainsman men of the saddle series 4 copeland lori on amazon com free shipping on qualifying offers the plainsman men of the saddle

**the maverick men of the saddle the men of the saddle series** - Jul 20 2023

web 3 93 643 ratings 39 reviews published 2005 11 editions trey mcallister is on his way home to tyrone kans want to read rate it the peacemaker men of the saddle

**the maverick men of the saddle book 3 kindle edition** - Mar 16 2023

web the maverick men of the saddle the men of the saddle series lori copeland on amazon com au free shipping on eligible orders the maverick men of the saddle

**the maverick men of the saddle book 3 amazon com** - Sep 22 2023

web sep 17 2019 award winning inspirational novelist lori copeland sets this tale of adventure faith romance and humor on the 1870s kansas missouri frontier when

**the maverick men of the saddle 3 allbookstores com** - May 06 2022

web the maverick men of the saddle 3 lori copeland 9780739457764 books amazon ca

**men of the saddle book series thriftbooks** - Jun 07 2022

web the maverick men of the saddle 3 by lori copeland click here for the lowest price hardcover 9780739457764 0739457764

**the maverick men of the saddle by lori copeland goodreads** - Oct 23 2023

web jan 1 2005 the maverick men of the saddle lori copeland 4 20 1 092 ratings50 reviews this third in the men of the saddle series takes readers back to an era when cowboys

*the maverick men of the saddle the men of the saddle series* - Dec 13 2022

web the maverick men of the saddle 3 by copeland lori isbn 10 0842386904 isbn 13 9780842386906 tyndale house publishers inc 2005 softcover

**men of the saddle series by lori copeland goodreads** - Jun 19 2023

web mar 10 2006 amazon com the maverick men of the saddle the men of the saddle series 9781664468122 lori copeland books

*the maverick men of the saddle by lori copeland cecilia ridett* - Jan 14 2023

web the maverick men of the saddle the men of the saddle series lori copeland amazon in books

the maverick men of the saddle book 3 by lori copeland - Jul 08 2022

web the men of the saddle book series by lori copeland includes books the peacemaker men of the saddle series 1 the drifter the maverick and several more see the

**the maverick men of the saddle 3 paperback** - Aug 21 2023

web the maverick men of the saddle the men of the saddle series lori copeland amazon sg books

**chemistry regents curve** - Sep 04 2022

web chemistry regents answer key answer booklet 57 kb scoring key pdf version 37 kb archive june 1998 august 2002  
physical setting chemistry january 2020 june 2012 108 show detail preview view more petition curve the nys chemistry  
regents change org

*scoring key chemistry regents curve blog theupside* - Dec 07 2022

web 4 scoring key chemistry regents curve 2019 10 24 the way snakes evolved how they are built and how they behave  
reproduce and survive in different habitats around the world it also highlights some of the most familiar and unique species  
found worldwide their current status what to do if you encounter a wild snake in

**january 2023 regents examination scoring information** - Feb 26 2022

web jan 24 2023 web posting times for scoring keys rating guides and conversion charts morning examinations 11 00 a m  
afternoon examinations 3 00 p m please note you must use adobe acrobat x or higher to open the secure pdfs for the above  
exams

june 2021 v202 regents examination scoring information - Jan 28 2022

web during the june 2021 v202 regents examination period june 17 21 25 2021 and for a period of time thereafter this site  
will provide as needed timely information and guidance on the administration and scoring of each of the regents  
examinations being administered this

**scoringkeychemistryregentscurve** - Jun 01 2022

web e3 chemistry guided study book 2018 home edition answer key included effiong eyo 2017 12 08 chemistry students and  
homeschoolers go beyond just passing enhance your understanding of chemistry and get higher marks on homework quizzes  
tests and the regents exam with e3 chemistry guided study book 2018 with e3 chemistry guided

**regents examination in physical setting chemistry june 2022** - Aug 15 2023

web chart for converting total test raw scores to final examination scores scale scores to determine the student s final  
examination score find the student s total test raw score in the column labeled raw score and then locate the scale score that  
corresponds to

**scoring information new york state education department** - Mar 10 2023

web archive for regents examination rating guides scoring keys conversation charts and important notices if any june 2023  
regents examinations january 2023 regents examinations august 2022 regents examinations june 2022 regents examinations  
june 2021 v202 regents examinations january 2020 regents examinations august 2019

**regents examination in physical setting chemistry june 2023** - Dec 27 2021

web chart for converting total test raw scores to final examination scores scale scores to determine the student s final  
examination score find the student s total test raw score in the column labeled raw score and then locate the scale score that

corresponds to

[scoring key chemistry regents curve](#) - Oct 05 2022

web kindly say the scoring key chemistry regents curve is universally compatible with any devices to read scoring key chemistry regents curve 2021 12 04 elena elianna sensory assessment of water quality e3 scholastic publishing the seminal book about iq and class that ignited one of the most explosive controversies in decades now updated

[chemistry regents curve 2020](#) - Jun 13 2023

web nächstes ziel 1 000 the nys chemistry regents is a assessment offered by the state in order to assess a students ability in the curriculum however the chemistry regents do not offer a curve which gives students a better opportunity of passing the test the requirements are often a score of 50 85 questions in order to pass with a score of 65

**how are regents examinations scored new york state education department** - Aug 03 2022

web this information is subjected to statistical analysis that places the questions on a scale of scores according to their level of difficulty the state tests and regents examinations use a scale of 0 to 100 raw scores must be converted to the equivalent scale score

[regents examination in physical setting chemistry](#) - Jul 14 2023

web aug 31 2023 scoring key pdf version 38 kb excel version 22 kb rating guide 83 kb conversion chart pdf version 135 kb excel version 14 kb june 2013 regents examination in ps chemistry regular large type and braille question 57 only 9 kb

january 2013 regents examination in physical setting chemistry 107 kb

**june 2023 regents examination scoring information** - Jan 08 2023

web jun 1 2023 during the june 2023 regents examination period june 1 14 16 20 23 2023 and for a period of time thereafter this site will provide as needed timely information and guidance on the administration and scoring of each of the regents examinations being administered this week

**chemistry regents curve 2022** - Apr 30 2022

web is there a curve on the 2022 chemistry regents answered 4 days ago scienceoxygen com sep 07 2022 september 7 2022 by alexander chemistry regents curve 2022 the exam is difficult because of its curve and long practical based syllabus read something else 199 show detail preview view more

[chemistry regents curve](#) - Nov 06 2022

web chemistry regents curve scoring the total test raw score is converted to a scaled score using a conversion chart that is specific to each exam the june 2013 conversion chart is shown below scoring 50 85 59 scales to a 65 while 75 85 88 scales to a 85 the math is correct you need to score 88 to achieve an 85 in the new

**june 2022 regents examination scoring information** - Mar 30 2022

web jun 15 2022 rating day during the june 2022 regents examination period june 15 17 21 24 2022 and for a period of time thereafter this site will provide as needed timely information and guidance on the administration and scoring of each of the regents examinations being administered this week

**regents examination in physical setting chemistry june 2019** - Apr 11 2023

web score score score score score score score score score 85 100 63 74 41 59 19 39 84 98 62 73 40 58 18 37 83 96 61 72 39 57 17 36 the chart above is usable only for this administration of the regents examination regents examination in physical setting chemistry june 2019 chart for converting total test raw scores to final

**scoring key chemistry regents curve pdf uniport edu** - Feb 09 2023

web aug 2 2023 scoring key chemistry regents curve 1 7 downloaded from uniport edu ng on august 2 2023 by guest scoring key chemistry regents curve as recognized adventure as skillfully as experience just about lesson amusement as skillfully as bargain can be gotten by just checking out a book scoring key chemistry regents curve next it

**does chemistry regents have a curve scienceoxygen** - Jul 02 2022

web sep 6 2022 the score you get on the chemistry regents might be lower than your actually score due to a negative curve here s how and why they are doing this they had to dumb down the test because such a large percentage of kids wouldnt t pass it this results in a large number of kids at the upper end getting very high grades table of

**for teachers only nysed** - May 12 2023

web regents high school examination physical setting chemistry wednesday june 20 2018 9 15 a m to 12 15 p m only scoring key and rating guide p s ch directions to the teacher refer to the directions on page 2 before rating student papers updated information regarding the rating of this examination may be

[tarendol wikipedia](#) - Aug 16 2023

web tarendol est un roman de l écrivain français rené barjavel paru en 1946 contrairement aux œuvres les plus connues de son auteur il ne s agit pas d un roman de science fiction

**domaine des garelles bellecombe tarendol fransa** - Jan 29 2022

web domaine des garelles bellecombe tarendol tarafsız yorumları okuyun gerçek gezgin fotoğraflarına bakın tripadvisor ın interaktif haritasını kullanarak konuma ve yakındaki restoran ve gezilecek yer seçeneklerine göz atın konaklamanız için fiyatları karşılaştırın ve en iyi teklifi alın

[barjavel rene tarendol v 2 0 archive org](#) - May 01 2022

web nov 13 1994 barjavel rene tarendol v 2 0 addeddate 2023 06 29 05 02 09 identifier barjavel rene tarendol v 2 0 identifier ark ark 13960 s25z5cv5tt1 ocr tesseract 5 3 0 3 g9920

*tarendol teaser youtube* - Jan 09 2023

web about press copyright contact us creators advertise developers terms privacy policy safety how youtube works test new features nfl sunday ticket press copyright

**tarendol tv movie 1980 florence pernel as marie imdb** - Sep 05 2022

web tarendol tv movie details full cast and crew release dates official sites company credits filming production technical specs

**tarendol 1980 turkcealtyazi org türkçe altyazı** - Mar 11 2023

web tarendol 1980 turkcealtyazi org türkçe altyazı tarendol

*tarendol tv series 1980 1980 the movie database tmdb* - Dec 08 2022

web jean tarendol 4 episodes florence pernel marie 4 episodes michel duchaussoy l auteur 4 episodes daniel gélin bazalo 4 episodes

tarendol tv movie 1980 full cast crew imdb - May 13 2023

web tarendol tv movie 1980 cast and crew credits including actors actresses directors writers and more

*tarendol 1980 starring florence pernel* - Feb 10 2023

web tarendol france children s cast florence pernel 17 marie last poll results what is your favorite movie genre recent releases action comedy horror crime family sci fi drama short thriller fantasy musical our partners children in cinema youth in cinema children in media

*tarendol tv movie 1980 release info imdb* - Oct 06 2022

web tarendol tv movie 1980 on imdb movies tv celebs and more menu movies release calendar top 250 movies most popular movies browse movies by genre top box office showtimes tickets movie news india movie spotlight tv shows what s on tv streaming top 250 tv shows most popular tv shows browse tv shows by genre tv

**the tragic innocents wikipedia** - Jul 15 2023

web the tragic innocents french tarendol is a 1946 novel by the french writer rené barjavel it tells the story of two teenagers jean tarendol and marie margherite who fall in love in occupied france during world war ii the story is set in an imaginary region inspired by the author s native drôme

tarendol free download borrow and streaming internet archive - Apr 12 2023

web tarendol publication date 1946 collection inlibrary printdisabled internetarchivebooks digitizing sponsor kahle austin foundation contributor internet archive language english notes cut off text close to the gutter access restricted item true addeddate 2023 03 10 23 27 49 boxid ia40146919 camera usb ptp class camera

**tramadol nedir ve ne için kullanılır sağlığa bir adım** - Jun 02 2022

web dec 21 2022 tramadol tıp uzmanlarının ağrıyı hafifletmek için reçete ettiği bir ilaçtır ağrıyı omurilik ve beynin spesifik

sinir hücrelerine etki ederek giderir bu ilaç opioid ailesine aittir bununla birlikte tramadol diğer opioid ilaçlardan farklı davranır ancak bu ilacın etki mekanizmasını ayrıntılı olarak daha sonra

**tramadol nedir ne demek** - Feb 27 2022

web tramadol nedir ve tramadol ne demek sorularına hızlı cevap veren sözlük sayfası tramadol anlamı tramadol ingilizcesi ingilizcede tramadol tramadol nnd

editions of tarendol by rené barjavel goodreads - Nov 07 2022

web editions for tarendol 2070361691 mass market paperback published in 1972 2207226131 paperback published in 1980 paperback published in 1981 ki

*tarendol tv movie 1980 plot imdb* - Jun 14 2023

web in 1943 in milon an imaginary small town in the south of france jean tarendol was a senior high school student with his comrade fiston they are going to steal strawberries from the principal s vegetable garden on their return they see a naked young girl cooling off on this hot spring night jean immediately falls in love with this young

**tramadol nedir hangi durumlarda kullanılır probiyotix com** - Aug 04 2022

web aug 12 2020 tramadol narkotik benzeri bir ağrı kesicidir tramadol yetişkinlerde orta ve şiddetli ağrıları tedavi etmek için kullanılır uzun süreli salınan tramadol formu günün her saati ağrı tedavisi içindir uzun süreli salınan tramadol formu ağrı için ihtiyaç duyulan bir temelde kullanılmak üzere değildir

**bellecombe tarendol da gezilecek en iyi yer tripadvisor** - Jul 03 2022

web bellecombe tarendol gezilecek yerler bellecombe tarendol mutlaka yapılması gereken şey için tripadvisor gezginlerinin 42 yorumuna ve fotoğrafına bak

**pdf tarendol by rené barjavel ebook perlego** - Dec 28 2021

web barjavel r 2023 tarendol edition unavailable l orma editore available at perlego com book 4195730 tarendol pdf accessed 17 august 2023

**tarendol tv movie 1980 parents guide imdb** - Mar 31 2022

web tarendol tv movie 1980 parents guide and certifications from around the world